

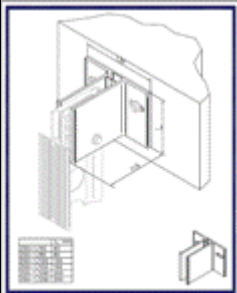

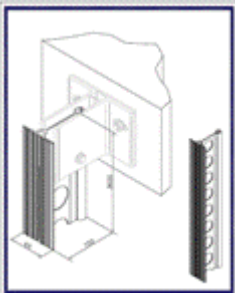
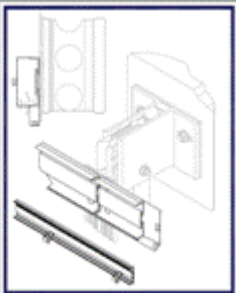
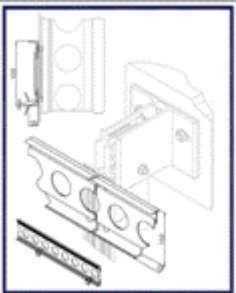
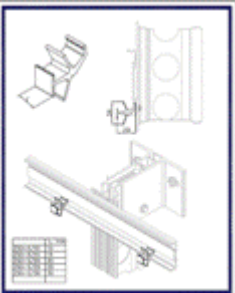
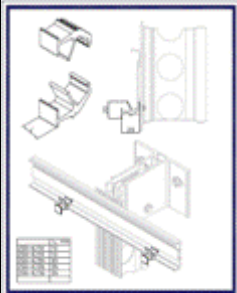
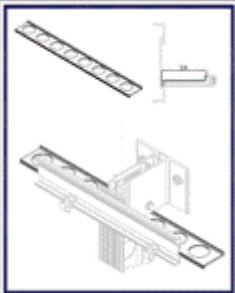
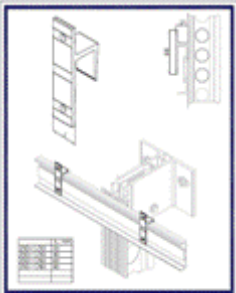
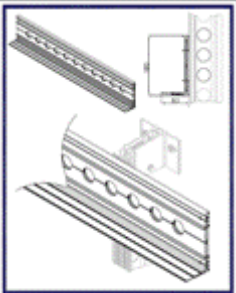
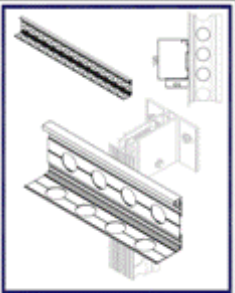
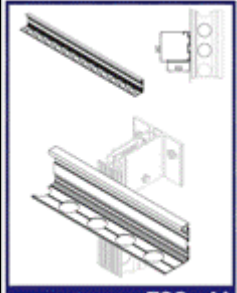
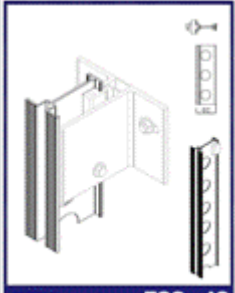
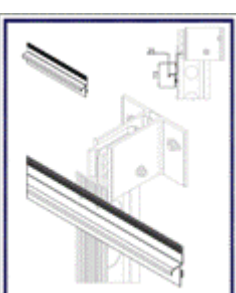
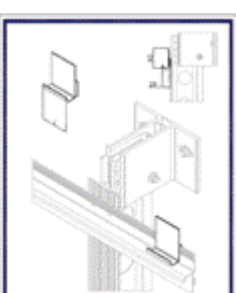
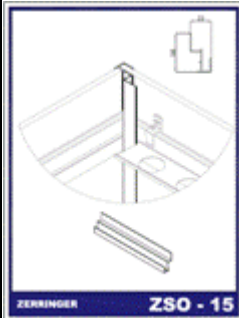
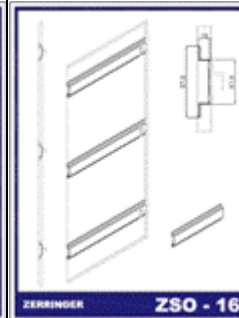
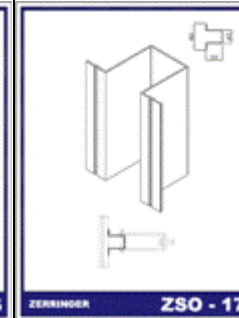

# ZERRINGER® Aluminium System Profiles

 <p>ZERRINGER <b>ZSO - 1</b></p>	 <p>ZERRINGER <b>ZSO - 2</b></p>	 <p>ZERRINGER <b>ZSO - 3</b></p>	 <p>ZERRINGER <b>ZSO - 4</b></p>	 <p>ZERRINGER <b>ZSO - 5</b></p>
<b>ZSO-1</b>	<b>ZSO-2</b>	<b>ZSO-3</b>	<b>ZSO-4</b>	<b>ZSO-5</b>
 <p>ZERRINGER <b>ZSO - 6</b></p>	 <p>ZERRINGER <b>ZSO - 7</b></p>	 <p>ZERRINGER <b>ZSO - 8</b></p>	 <p>ZERRINGER <b>ZSO - 9</b></p>	 <p>ZERRINGER <b>ZSO - 10</b></p>
<b>ZSO-6</b>	<b>ZSO-7</b>	<b>ZSO-8</b>	<b>ZSO-9</b>	<b>ZSO-10</b>
 <p>ZERRINGER <b>ZSO - 11</b></p>	 <p>ZERRINGER <b>ZSO - 12</b></p>	 <p>ZERRINGER <b>ZSO - 13</b></p>	 <p>ZERRINGER <b>ZSO - 14</b></p>	
<b>ZSO-11</b>	<b>ZSO-12</b>	<b>ZSO-13</b>	<b>ZSO-14</b>	

## ZERRINGER® Useful Profiles

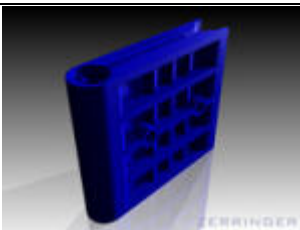
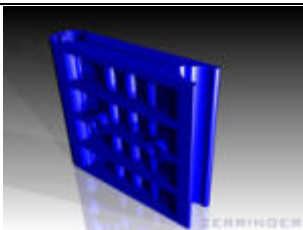
				
<p>ZERRINGER ZSO - 15</p>	<p>ZERRINGER ZSO - 16</p>	<p>ZERRINGER ZSO - 17</p>		
<p>ZSO-15</p>	<p>ZSO-16</p>	<p>ZSO-17</p>		

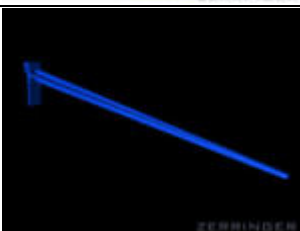
## ZERRINGER® Plastic Elements

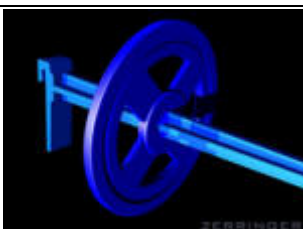
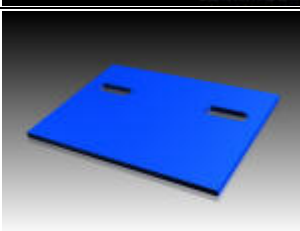
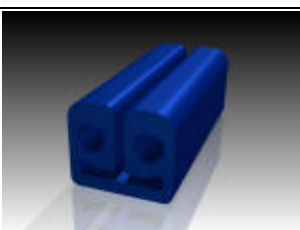
<p>ZERRINGER® Cartridge</p>		
<p>ZERRINGER® Ring</p>		
<p>ZERRINGER® Spike</p>		
<p>ZERRINGER® Spike-ring assembly</p>		
<p>ZERRINGER® Gasket</p>		
<p>ZERRINGER® Sleeve</p>		

## ZERRINGER® Metal Forming Lightweight Machines

- ❑ Length 3000 mm.
- ❑ Maximum metal thickness: 1.5 mm - for aluminum; 1.2 mm - for steel.
- ❑ Maximum weight - 380 kg.
- ❑ Maximum depth of bending: 450 mm for 3000 mm wide sheets; unlimited for 1520 mm wide sheets.
- ❑ Portable.

